

Laser Measuring Device LE 200 - PB

TR-VLE-TI-GB-0110
06/12 Revision 07
010203-02000302-XXXX

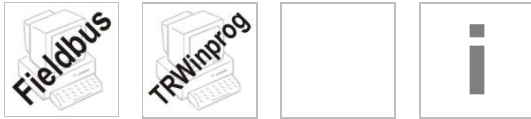

- + PROFIBUS-DP / SSI - interface
- + Robust
- + Measurement of linear movement
- + Non contact distance measurement
- + Measuring distance up to 125 m, 170 m, 195 m, 240 m other distances on request
- + Parametrizable
- + Further interfaces available
- + Customized adaptations upon request

Characteristics

Supply voltage.....	Standard: 18...27 V DC \pm 5 %, with heating: 24 V DC \pm 5 %
Current consumption, without load.....	Standard: < 350 mA, with heating: < 2.5 A
Measurement principle.....	Phase shift measurement
Measuring length, against reflector foil	0.2...125 m standard, 170 m, 195 m, 240 m (special devices)
Resolution selectable ¹⁾	physical resolution 0.1 mm
Linearization	
- up to 12 m, standard.....	absolute linearity error \pm 3 mm
- complete measuring length.....	absolute linearity error \pm 5 mm
Reproducibility	\pm 2 mm
Laser diode, red light.....	Laser Protection Class 2 according to DIN EN 60 825-1: 2003-10
- Wave length λ	670 nm
- Laser power	$P_{\max} \leq 1$ mW
- Lifetime, 25 °C	50 000 h
Measurand output / refresh rate	1000 values / s
Integration time	1 ms
Programmable via RS485	WINDOWS® compatible (TRWinProg) / PROFIBUS-DP
Profibus-DP V0	IEC 61158, IEC 61784
- Output code	Binary
- Addressing	3...99, adjustable by means of rotary switches
- Baud rate	9.6 kbit/s...12 Mbit/s
- Parameter ¹⁾	Count direction, Resolution, Preset value, speed, among others
SSI	Synchronous-Serial-Interface
- Clock input.....	Optocoupler
- Data output.....	RS-422, 2-wire
- Clock frequency.....	80 kHz...820 kHz
- Output code ¹⁾	Binary, Gray
- Number of data bits ¹⁾	12...26, with error bit transmission
- SSI output ¹⁾	Position, Intensity, Speed
Speed output.....	16 bit; Accuracy: \pm 10 % related to the output value
Switching input / Switching output ¹⁾	
- Levels switching input.....	1-level > +8 V, 0-level < +2 V, up to \pm 35V, 5 kOhm
- Levels switching output	1-level > US-2 V, 0-level < 1 V, up to 100 mA

¹⁾ programmable parameter

Subject to change

Environmental conditions

Vibration, DIN EN 60068-2-6: 1996	≤ 50 m/s ² , sine 50-2000 Hz
Shock, DIN EN 60068-2-27: 1995.....	≤ 300 m/s ² , half-sine 11ms
EMC	
- Immunity to disturbance, DIN EN 61000-6-2: 2006	
- Transient emissions, DIN EN 61000-6-3: 2007	
Working temperature	
- Standard	0...50 °C
- With heating	-30 °C...+50 °C
Storage temperature	-20 °C...+75 °C, dry
Thermal drift, related to the max. measuring length.....	1 ppm / °C at 125 m, 170 m, 195 m or 240 m
Relative humidity, DIN EN 60068-3-4: 2002	98 %, non condensing
Protection class, DIN EN 60529: 1991 ²⁾	IP 65

²⁾ valid with screwed on mating connector and / or screwed together cable gland

Dimension drawing

(For project planning please request customized dimensional drawing!)

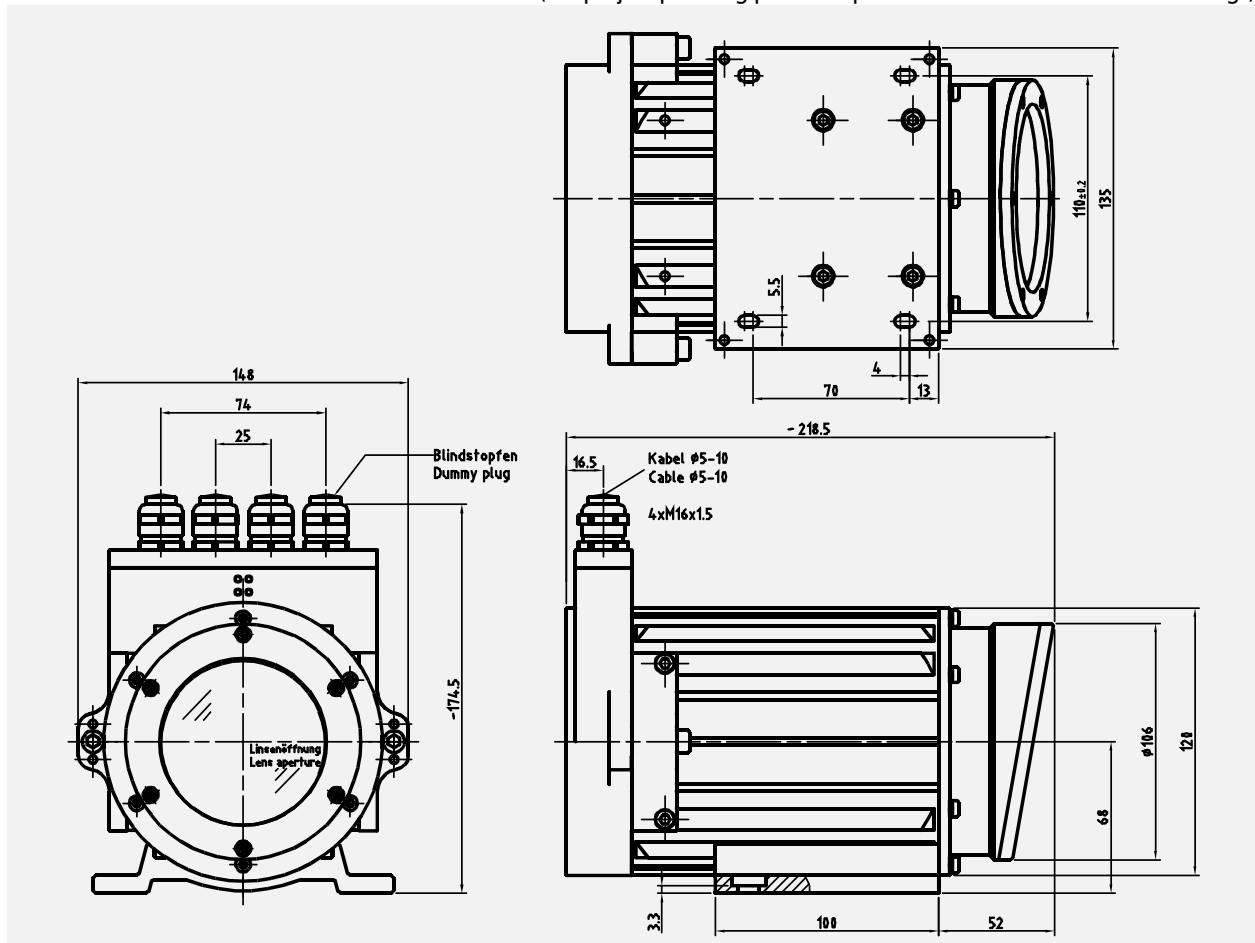

Subject to change