



Dichiarazione CE di conformità
EC declaration of conformity

Torino, 1/1/2010

REER SpA
via Carcano 32
10153 – Torino
Italy

dichiara che le barriere fotoelettriche **VISION VXL / VISION MXL** sono Dispositivi Elettrosensibili di Sicurezza (ESPE) di :

- **Tipo 2** (secondo la Norma *CEI EN 61496-1:2005; CEI EN 61496-2:2007*)
- **SIL 2** (secondo la Norma *CEI EN 61508:2002*)
- **SILCL 2** (secondo la Norma *CEI EN 62061:2005 + CEI EN 62061/EC2:2008*)
- **PL d** (secondo la Norma *UNI EN ISO 13849-1:2008*)

declares that the **VISION VXL / VISION MXL** photoelectric safety barriers are :

- **Type 2** (according the Standard *IEC 61496-1:2004; IEC 61496-2:2006*)
- **SIL 2** (according the Standard *IEC 61508:1998*)
- **SILCL 2** (according the Standard *IEC 62061:2005*)
- **PL d** (according the Standard *ISO 13849-1:2006*)

Electro-sensitive Protective Equipments (ESPE)

realizzati in conformità alle seguenti Direttive Europee:
complying with the following European Directives:

- **2006/42/CE** "Direttiva Macchine"
"Machine Directive"
- **2004/108/CE** "Direttiva Compatibilità Elettromagnetica"
"Electromagnetic Compatibility Directive"
- **2006/95/CE** "Direttiva Bassa Tensione"
"Low Voltage Directive"

e sono identiche all'esemplare esaminato ed approvato con esame di tipo CE da:
and are identical to the specimen examined and approved with a CE - type approval by:

TÜV SÜD Rail GmbH – Ridlerstrasse 65 – D-80339 – Muenchen – Germany

Carlo Pautasso
Direttore Tecnico
Technical Director

Giancarlo Scaravelli
Presidente
President

*PHOTOELECTRIC
SAFETY
BARRIER*

VISION VXL

INSTALLATION USE AND MAINTENANCE

INDICE

INTRODUCTION	2
OPERATION.....	3
INSTALLATION	4
POSITION	5
SAFETY DISTANCE CALCULATION.....	6
VERTICAL POSITION OF THE BARRIER	7
HORIZONTAL POSITION OF THE BARRIER	8
ELECTRICAL CONNECTIONS	9
EMITTER CONNECTIONS.....	9
RECEIVER CONNECTIONS	10
WARNINGS REGARDING THE CONNECTION CABLES.....	10
EXAMPLE OF CONNECTION WITH AD SR0 WITH START/RESTART INTERLOCK ACTIVATED..	12
CONFIGURATION AND OPERATION MODES.....	12
K1/K2 EXTERNAL CONTACTORS CONNECTION.....	13
MULTIPLE SYSTEMS	13
USE OF DEFLECTION MIRRORS.....	15
DISTANCE BETWEEN REFLECTING SURFACES	16
MECHANICAL ASSEMBLY AND OPTICAL ALIGNMENT.....	17
OPERATION AND TECHNICAL DATA	18
SIGNALS.....	18
TEST FUNCTION	20
PERIODICAL SYSTEM TEST	20
OUTPUT STATUS	20
TECHNICAL SPECIFICATIONS.....	21
DIMENSIONS	22
CHECKOUTS AND MAINTENANCE	24
VERIFICATION OF BARRIER EFFICIENCY	24
TROUBLESHOOTING	25
SPARE PARTS.....	27
GUARANTEE	28



This symbol stands by a very important warning concerning the safety of persons. Its non-observance can cause a very serious risk for the exposed personnel.

INTRODUCTION

The VISION VXL photoelectric barrier is a multi-beam optoelectronic safety system.

It belongs to the family of Type 2 electrosensitive devices for the protection of personnel exposed to risks arising from the use of hazardous machinery or plant, according to standards IEC 61496-1,2 and EN 61496-1.

VISION VXL is a Type 2 photoelectric barrier composed of Emitter and Receiver with integration of additional functions, such as the external contactors feedback control and the manual/automatic operation management.

The LEDs present on Emitter and Receiver units labels provides the necessary information for a correct use of the device and the evaluation of the possible operation defects.

The VISION VXL barrier system features an automatic self-diagnosis function that enables it to detect every malfunctions (in an maximum execution time of 0,5 sec).

This safety system is permanently active and does not require any interventions from the outside.



If necessary, for any safety-related problems contact the competent safety authorities or industrial associations in the country of use.



For applications in the food industry, please contact the manufacturer to ensure that the barrier contains materials that are compatible with the chemical agents utilized.

The protective function of the optoelectronic devices is not effective in the following cases:



If the machine stopping control cannot be actuated electrically and it is not possible to stop all dangerous machine movements immediately and at any time during the operating cycle.



If the machine generates dangerous situations due to material being expelled or falling from overhead.



Carefully consider the risks analysis of the application and the legislation of the barrier application Country to establish if the application is compatible with the safety category 2.

OPERATION

If the protected area is clear, the two outputs on the Receiver are active and enable the machine to which they are connected to operate normally.

Each time that an object bigger than or equal in size to the resolution of the system intercepts the optical path of one or more beams, the Receiver deactivates the outputs.

This condition enables hazardous machine movements to be stopped (by means of an adequate machine emergency stop circuit).



The resolution is the minimum dimensions that an object must have so that, on crossing the protected area, it will certainly intercept at least one of the optical beams generated by the barrier (Figure 1).

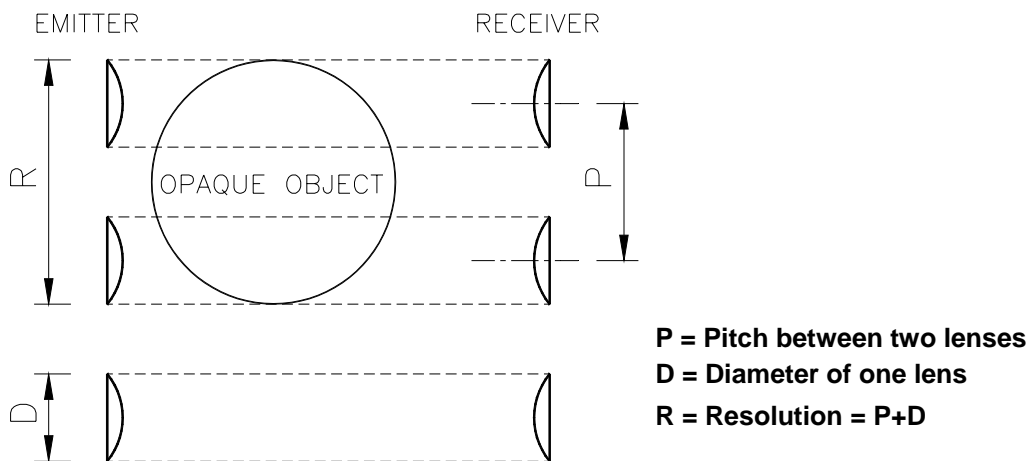

Figure 1

The resolution is constant irrespectively of work conditions, as it only depends on the geometric characteristics of the lenses and the distance between the centres of two adjacent lenses.

The **height of the protected area** is the height that is actually protected by the safety barrier. If the latter is placed horizontally, this value refers to the depth of the protected area.

The **working range** is the maximum operative distance that can exist between the Emitter and the Receiver.

VISION VXL is available with the following resolutions:





- 30 mm (protected height from 150 mm to 1200 mm)
PROTECTION OF HANDS
- 40 mm (protected height from 300 mm to 1200 mm)
PROTECTION OF HANDS

VISION VXL is available also in the **Multibeam** configuration with the following lens pitch:

- 500mm (2 beams), 400mm (3 beams), 300mm (4 beams).
PROTECTION OF BODY

INSTALLATION



Before installing the VISION VXL safety system, make sure that:

-  ***The safety system is only used as a stopping device and not as a machine control device.***
-  ***The machine control can be actuated electrically.***
-  ***All dangerous machine movements can be interrupted immediately. In particular, the machine stopping times must be known and, if necessary, measured.***
-  ***The machine does not generate dangerous situations due to materials projecting or falling from overhead; if that is not the case, additional mechanical guards must be installed.***
-  ***The minimum dimensions of the object that must be intercepted are greater than or equal to the resolution of the specific model.***

Knowledge of the shape and dimensions of the dangerous area enables the width and height of the relative access area to be calculated.

-  ***Compare these dimensions with the maximum working range and the height of the protected area in relation to the specific model.***

The general instructions set out below must be taken into consideration before placing the safety device in position.

-  ***Make sure that the temperature of the environment in which the system is to be installed is compatible with the temperature parameters contained in the technical data sheet.***
-  ***Do not install the Emitter and Receiver close to bright or high-intensity flashing light sources.***
-  ***Certain environmental conditions may affect the monitoring capacity of the photoelectric devices. In order to assure correct operation of equipment in places that may be subject to fog, rain, smoke or dust, the appropriate correction factors Cf should be applied to the maximum working range values. In these cases:***

$$Pu = Pm \times Cf$$

where Pu and Pm are, respectively, the working and maximum range in meters.

The recommended Cf factors are shown in the table below:

ENVIRONMENTAL CONDITION	CORRECTION FACTOR Cf
Fog	0.25
Steam	0.50
Dust	0.50
Dense fumes	0.25

⚠ *If the device is installed in places that are subject to sudden changes in temperature, the appropriate precautions must be taken in order to prevent the formation of condensation on the lenses, which could have an adverse effect on monitoring.*

POSITION

The position of the *VXLE* Emitter and the *VXLR* Receiver must prevent access to the danger zone from above, below and from the sides, unless at least one of the optical beams has been intercepted. Some useful information regarding the correct position of the barrier is shown in the figure below.

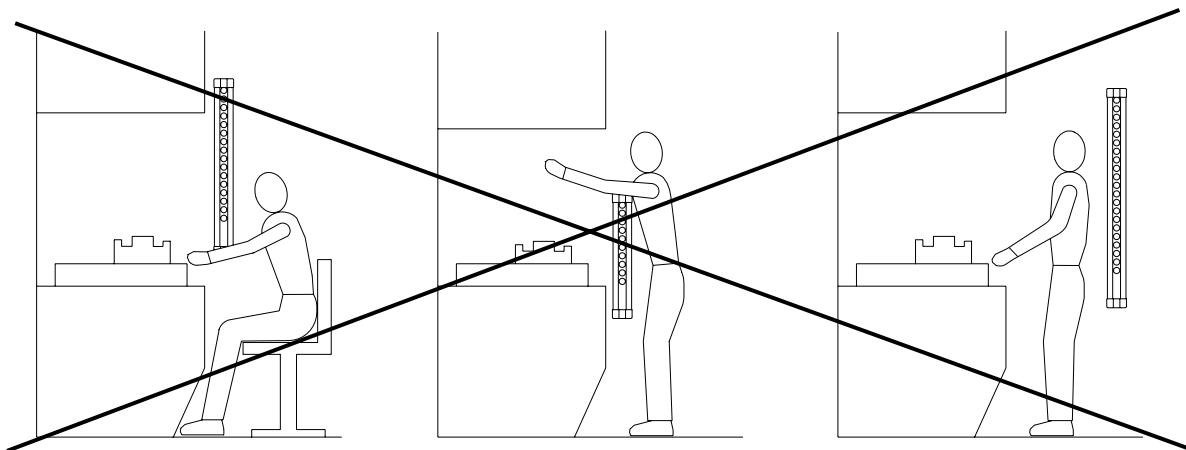

Incorrect positioning of barrier

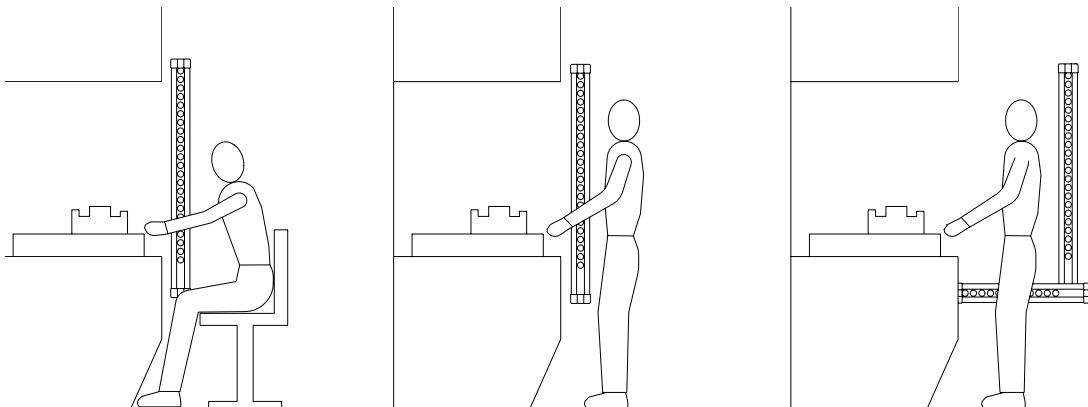

Correct positioning of barrier

Figure 2

SAFETY DISTANCE CALCULATION



The barrier must be installed at a distance that is greater than or equal to the **minimum safety distance S**, so that a dangerous point can only be reached after all hazardous machine movements have stopped (Figure 3).

According to European standard EN999, the minimum safety distance **S** must be calculated using the following formula:

$$S = K(t_1 + t_2) + C$$

where:

S	<i>minimum safety distance</i>	mm
K	<i>approach speed of object to the dangerous area</i>	mm/sec
t₁	<i>response time of the safety barrier in seconds</i>	sec
t₂	<i>machine response time, in seconds, meaning the time required for the machine to interrupt the dangerous movement following transmission of the stop signal</i>	sec
c	<i>additional distance</i>	mm

-  **The non-observance of the correct safety distance reduces or cancels the protective action of the light curtain.**
-  **If the position of the barrier does not prevent the operator from having access to the dangerous area without being detected, additional mechanical guards must be installed to complete the system.**

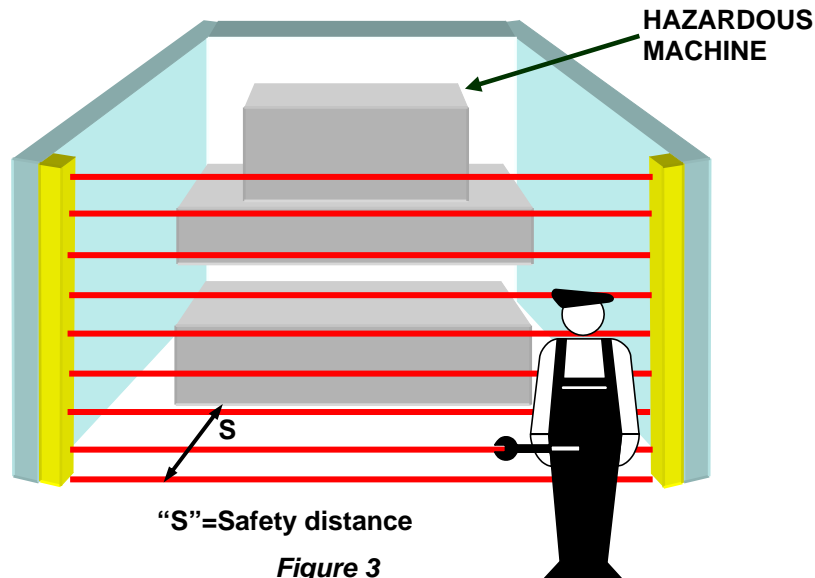

VERTICAL POSITION OF THE BARRIER

30 mm and 40 mm resolution models.



These models are suitable for the protection of hands.

The minimum safety distance **S** is calculated according to the following formula:

$$S = 2000(t_1 + t_2) + 8(D-14)$$

(D=resolution)

This formula is valid for distances **S** between 100 and 500 mm. If this formula results in **S** being greater than 500 mm, the distance can be reduced to a minimum of 500 mm by means of the following formula:

$$S = 1600(t_1 + t_2) + 8(D-14)$$

If, due to the specific configuration of the machine, the dangerous area can be accessed from above, the highest beam of the barrier must be at a height **H** of at least 1800 mm from the base **G** of the machine.

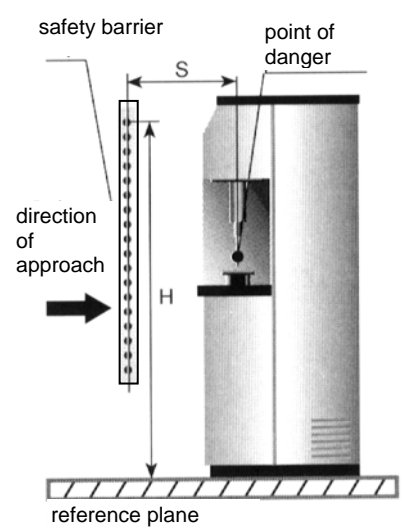

Figure 4

Multibeam Models.



These models are suitable for the protection of the entire body and must not be used to protect arms or legs.

The minimum safety distance **S** is calculated according to the following formula:

$$S = 1600 (t_1 + t_2) + 850$$

➔ The recommended height **H** from the base (G) must be the following:

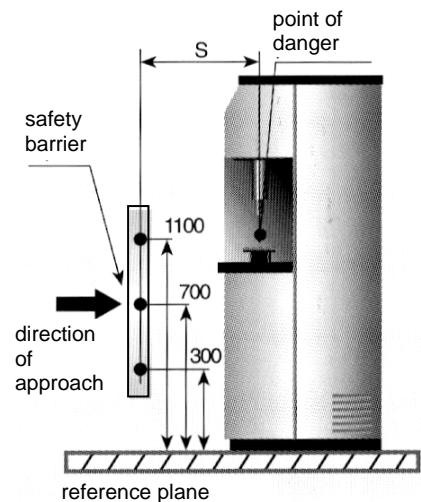

Figure 5

MODEL	BEAMS	Recommened Height H (mm)
VXL 2B	2	400 – 900
VXL 3B	3	300 – 700 – 1100
VXL 4B	4	300 – 600 – 900 - 1200

HORIZONTAL POSITION OF THE BARRIER

When the object's direction of approach is parallel to the floor of the protected area, the barrier must be installed so that the distance between the outer limit of the dangerous area and the most external optical beam is greater than or equal to the minimum safety distance **S** calculated as follows:

$$S = 1600(t_1 + t_2) + 1200 - 0.4H$$

where **H** is the height of the protected surface from the base of the machine;

$$H = 15(D-50)$$

(D=resolution)

In this case, H must always be less than 1 meter.

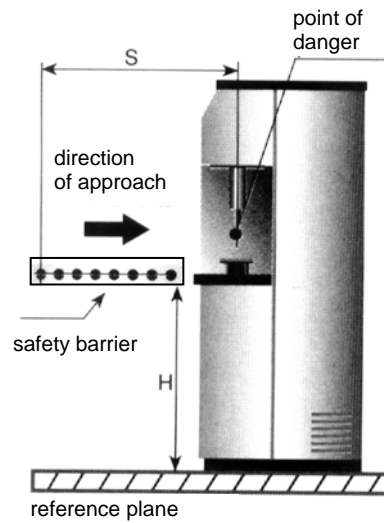

Figure 6

ELECTRICAL CONNECTIONS

WARNINGS

Before making the electrical connections, make sure that the supply voltage complies with that specified in the technical data sheet.



Emitter and Receiver units must be supplied with 24Vdc±20% power supply that guarantee safe isolation from main voltage.



The external power supply must comply with the standard EN 60204-1 (Chapter 6.4).

The electrical connections must be made according to the diagrams in this manual. In particular, do not connect other devices to the connectors of the Emitter and Receiver.

For reliability of operation, when a diode jumper supply unit is used, its output capacity must be at least 2000µF for each absorbed A.

EMITTER CONNECTIONS

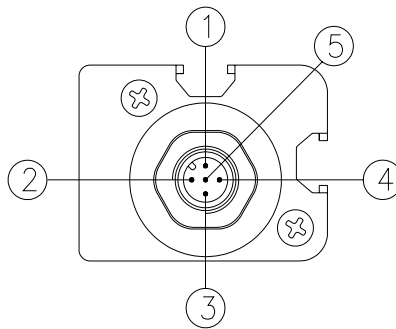

5 poles M12 connector

PIN	COLOR	NAME	TYPE	DESCRIPTION	FUNCTIONING
1	Brown	24VDC	INPUT	+24VDC power supply	-
3	Blue	0VDC		0VDC power supply	-
5	Grey	FE		Ground connection	-
2	White	TEST	-	TEST request	- Operation without TEST (+24VDC) - TEST request (Transition +24VDC -> 0VDC or open circuit)
4	Black	N.C.	-	N.C.	-

Table 1

RECEIVER CONNECTIONS

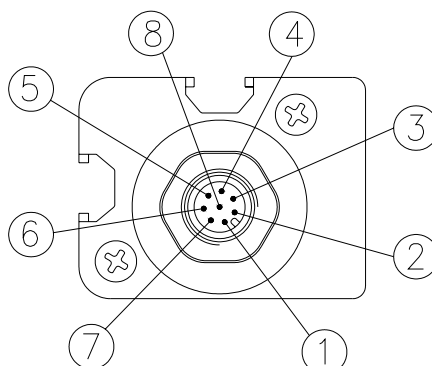

8 poles M12 connector

PIN	COLOR	NAME	TYPE	DESCRIPTION	FUNCTIONING
2	Brown	24VDC	-	+24VDC power supply	-
7	Blue	0VDC	-	0VDC power supply	-
8	Red	FE	-	Ground connection	-
1	White	OSSD1	OUTPUT	Safety static outputs	PNP active high
3	Green	OSSD2	OUTPUT		
5	Grey	SEL_A	INPUT	Barrier configuration	According the normative EN61131-2 (ref. Par. "Configuration and operation modes")
6	Pink	SEL_B	INPUT		
4	Yellow	K1_K2	INPUT	External contactors Feedback	

Table 2

WARNINGS REGARDING THE CONNECTION CABLES

- For connections over 50m long, use cables with a cross-section area of 1 mm².
- The power supply to the barrier should be kept separate from that to other electric power equipment (electric motors, inverters, frequency converters) or other sources of disturbance.
- Connect the Emitter and the Receiver to the ground outlet.
- The connection cables must follow a different route to that of the other power cables.

**Example of connection in MANUAL mode
with external contactors K1-K2**

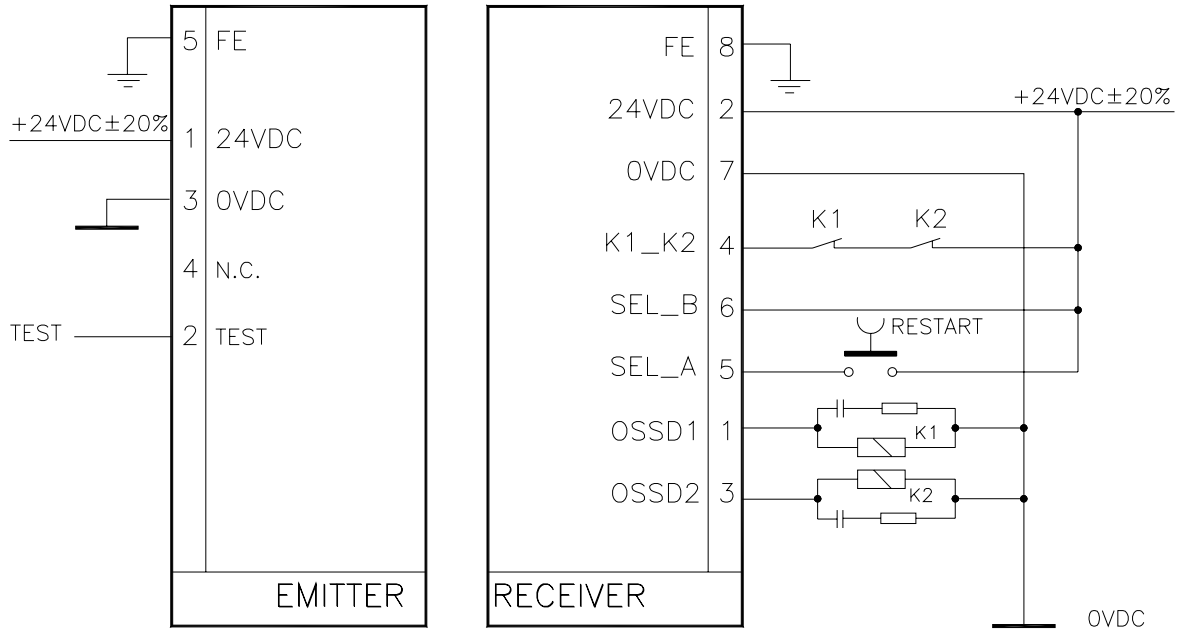

Figure 7

**Example of connection in AUTOMATIC mode
with external contactors K1-K2**

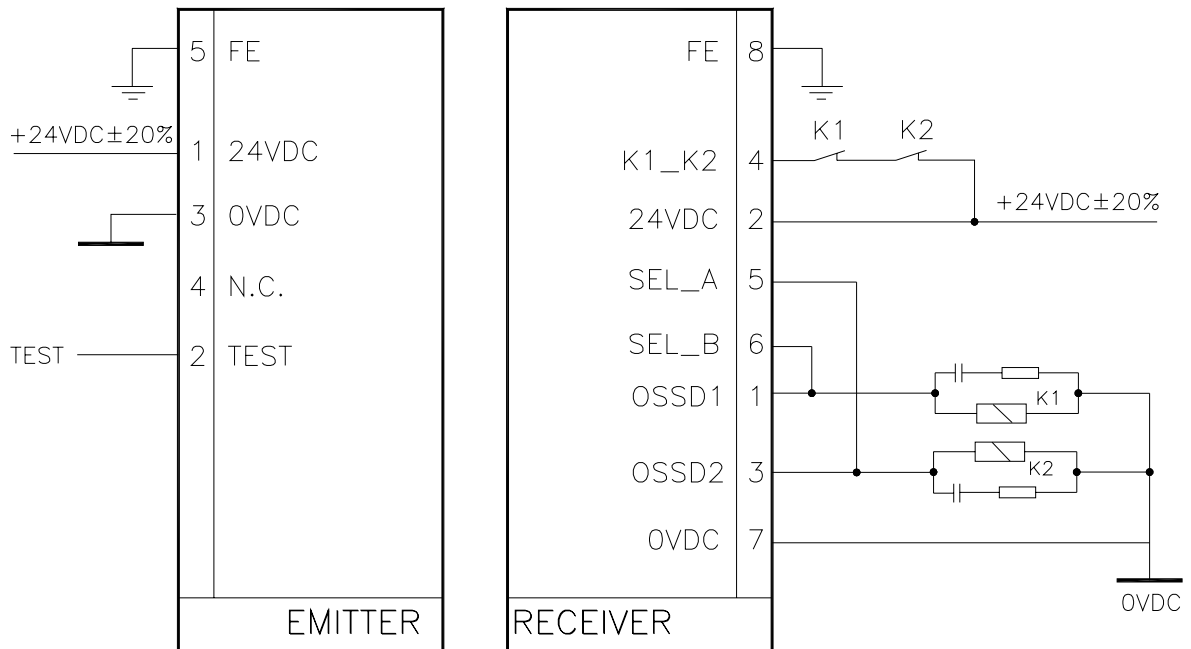
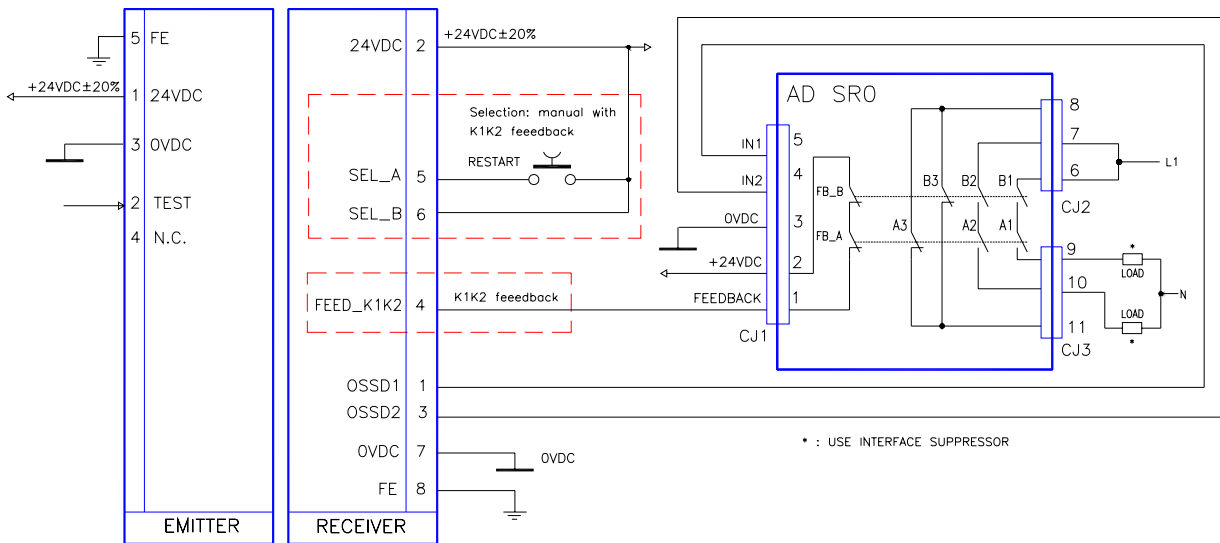

Figure 8

➔ *If the TEST function is not required by the application, connect pin 2 of the emitter to +24Vdc.*

EXAMPLE OF CONNECTION WITH AD SR0 WITH START/RESTART INTERLOCK ACTIVATED



CONFIGURATION AND OPERATION MODES

The VISION VXL operation mode is selected realizing appropriate connections on the M12 8 poles of the Receiver (Table 3 and Table 4).

AUTOMATIC MODE



The VISION VXL light curtain does not dispose of a start/restart interlock circuit in automatic mode. In most applications this safety function is necessary. Please consider the risk-analysis of your application about this matter.

In AUTOMATIC functioning, the two static outputs OSSD1 and OSSD2 follow the status of the guarded opening.

- with the area guarded clear, the outputs will supply +24VDC
- with the area occupied they will supply 0VDC.

CONNECTION		OPERATION MODE
SEL_A (PIN 5) connected to : OSSD1 (PIN 1)	SEL_B (PIN 6) connected to : OSSD2 (PIN 3)	K1_K2 (PIN 4) connected to : 0VDC
AUTOMATIC without K1-K2 feedback control		
SEL_A (PIN 5) connected to : OSSD2 (PIN 3)	SEL_B (PIN 6) connected to : OSSD1 (PIN 1)	K1_K2 (PIN 4) connected to : 24VDC (through series of contacts N.C. of external relays)
AUTOMATIC with K1-K2 feedback control		

Table 3

MANUAL MODE

⚠ Use of manual mode (start/restart interlock activated) is compulsory if the safety device controls an opening to protect a danger area and a person, after passing through the opening, may remain in the danger area without being detected (use as 'trip device' according to IEC 61496). Failure to comply with this rule may result in very serious hazards for the persons exposed.

In this operating mode the safety outputs OSSD1 and OSSD2 are activated (+24VDC) only if the protected area is free and after the reception of the RESTART signal, using a push button or thank to an appropriate control on the SEL_A or SEL_B input (ref. Table 4).

After an interception of the protected area, the safety outputs will be de-activated. To re-activate them it will be necessary to repeat the sequence described above.

The RESTART command is active with a voltage of +24VDC.

The minimum duration of the RESTART command is **100ms**.

CONNECTION			OPERATION MODE
SEL_A (PIN 5) connected to : 24VDC (PIN 2)	SEL_B (PIN 6) connected to : 24VDC (PIN 2) (through the RESTART pushbutton)	K1_K2 (PIN 4) connected to : 0VDC	MANUAL without K1-K2 feedback control
SEL_A (PIN 5) connected to : 24VDC (PIN 2) (through the RESTART pushbutton)	SEL_B (PIN 6) connected to : 24VDC (PIN 2)	K1_K2 (PIN 4) connected to : 24VDC (through series of contact N.C. of external relays)	MANUAL with K1-K2 feedback control

Table 4

K1/K2 EXTERNAL CONTACTORS CONNECTION

In every operating mode the K1/K2 external contactors feedback is activable.

If you want to use this control feature, connect the pin 4 of 8 poles M12 connector with the power supply (+24VDC) through the series of N.C. contacts (feedback) of external contactors.

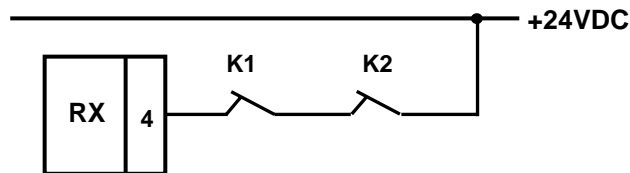

MULTIPLE SYSTEMS

When more than one VISION VXL system is used, precautions must be taken to avoid optical interference between them: install units so that the beam emitted by the Emitter of one system can only be received by the relative Receiver.

Figure 9 illustrates some examples of correct positioning when two photoelectric systems are installed. Incorrect positioning could generate interference, and may result in malfunctioning.

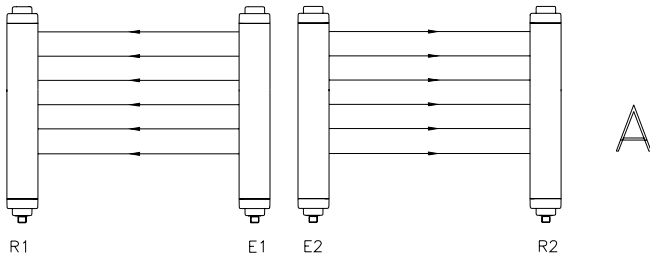

Systems installed alongside each other: A
Installation of two adjacent Emitters

Overlapping systems: B

L-shaped installation: C
Crossed positioning of Emitters and receivers

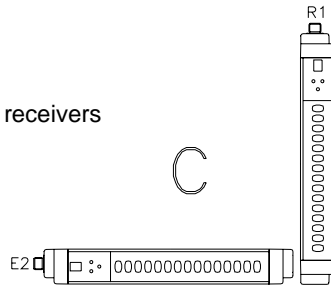
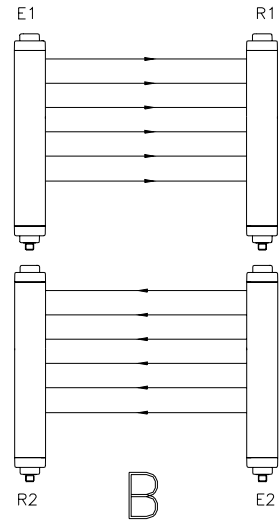

Figure 9

USE OF DEFLECTION MIRRORS

In order to protect or control areas that can be accessed from more than one side, in addition to the Emitter and Receiver, one or more deflection mirrors can be installed.

These mirrors enable the optical beams generated by the Emitter to be deviated on one or more sides.

If the beams emitted by the Emitter must be deviated by 90°, the perpendicular to the surface of the mirror must form an angle of 45° with the direction of the beams.

The following figure illustrates an application in which two deviation mirrors are used to provide a U-shaped protection.

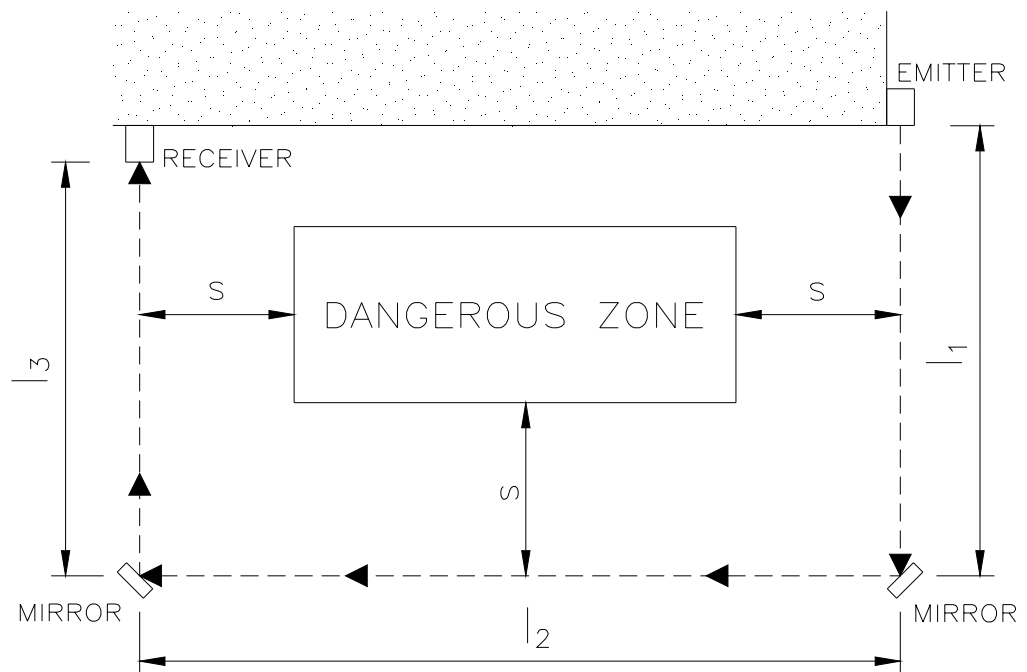

Figure 10

The following rules should be taken into consideration when using deviation mirrors:

- Place the mirrors so as to ensure compliance with the minimum safety distance **S** (Figure 10) on each side from which the danger zone can be accessed.
- The working distance (range) is given by the sum of the lengths of all the sides that give access to the protected area. (Remember that for each mirror used the maximum working range between the Emitter and the Receiver is reduced by 15%).
- During installation, take great care to avoid twisting along the longitudinal axis of the mirror.
- Make sure, by standing near to and on the axis of the Receiver, that the **entire outline** of the Emitter is visible on the first mirror.
- The use of more than three deviation mirrors is not recommended.

DISTANCE BETWEEN REFLECTING SURFACES

The presence of reflecting surfaces in proximity of the photoelectric barrier may generate spurious reflections that prevent monitoring. With reference to Figure 11, object **A** is not detected because surface **S** reflects the beam and closes the optical path between the Emitter and Receiver. A minimum distance **d** must therefore be maintained between any reflecting surfaces and the protected area. The minimum distance **d** must be calculated according to the distance **l** between the Emitter and the Receiver, considering that the angle of projection and reception is 5°.

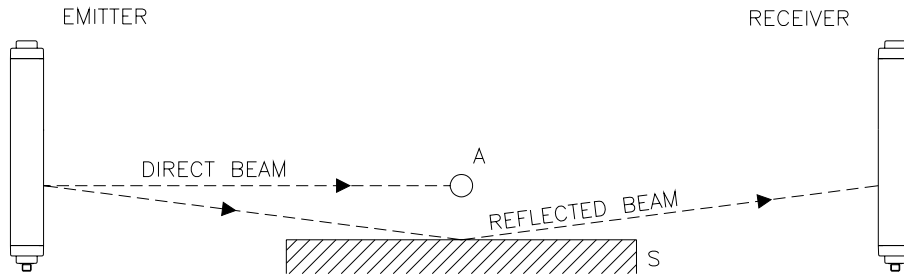

Figure 11

Figure 12 illustrates the values for the minimum distance **d** that must be maintained when the distance **l** between the Emitter and Receiver is changed.

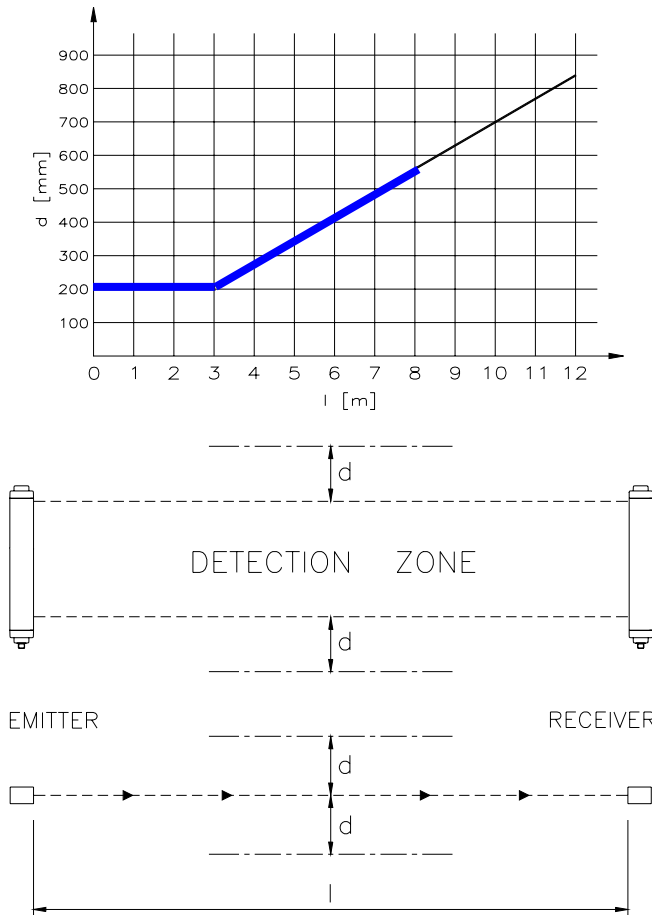

Figure 12

After installing the system, check whether any reflecting surfaces intercept the beams, first in the centre and then in the vicinity of the Emitter and Receiver. During these operations, the red LED on the Receiver should never, for any reason switch off.

MECHANICAL ASSEMBLY AND OPTICAL ALIGNMENT

The Emitter and the Receiver must be assembled opposite each other (at a distance specified in the technical data sheet). Use the **fastening brackets and inserts** supplied with the system to place the Emitter and the Receiver so that these are aligned and parallel to each other and with the connectors facing the same way.

Depending on the dimensions and the shape of the support on which they are to be installed, the Emitter and Receiver must be assembled with the fastening inserts at the back, or else by fitting these in the side groove (Figure 13).

Perfect alignment of the Emitter and Receiver is essential in order to assure correct barrier operation. The indicator LEDs on the Emitter and Receiver facilitate this operation.



To perform an easier alignment the use of SFB circular brackets is necessary. These are available on request (ordering code 1330974).

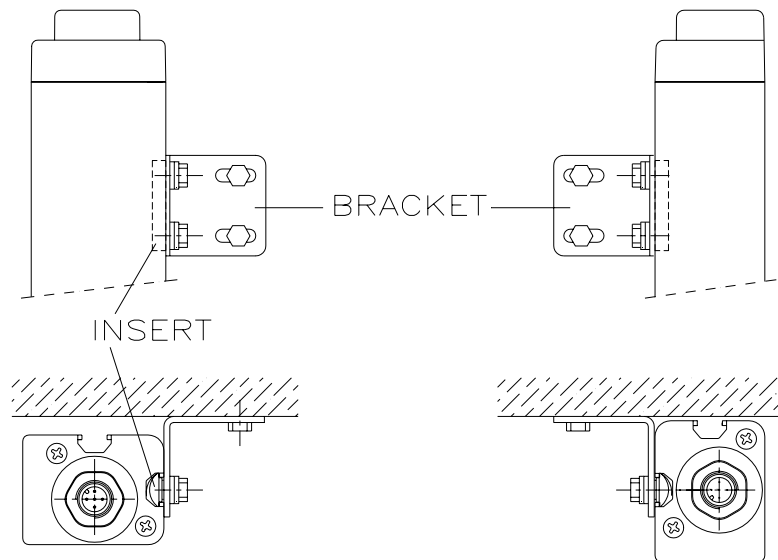

Figure 13

- Position the optical axis of the first and last beam of the Emitter on the same axis as that of the corresponding beams on the Receiver.
- Move the Emitter in order to find the area within which the green LED on the Receiver stays on, then position the first beam of the Emitter (the one close to the indicator LEDs) in the centre of this area.
- Using this beam as a pivot, effect small sideways movements of the opposite end to move to the protected area clear condition. The green LED on the Receiver will indicate this condition.
- Lock the Emitter and Receiver in place.



If the Emitter and the Receiver are assembled in areas that are subject to strong vibrations, **the use of vibration-damping supports is necessary**, in order to prevent circuit malfunctions (code SAV-3 1200088, code SAV-4 1200089).

OPERATION AND TECHNICAL DATA

SIGNALS

The LEDs showed on Emitter and Receiver units labels are visualized depending on the system operation phase. The tables below shows the different signals (ref. Figure 14).

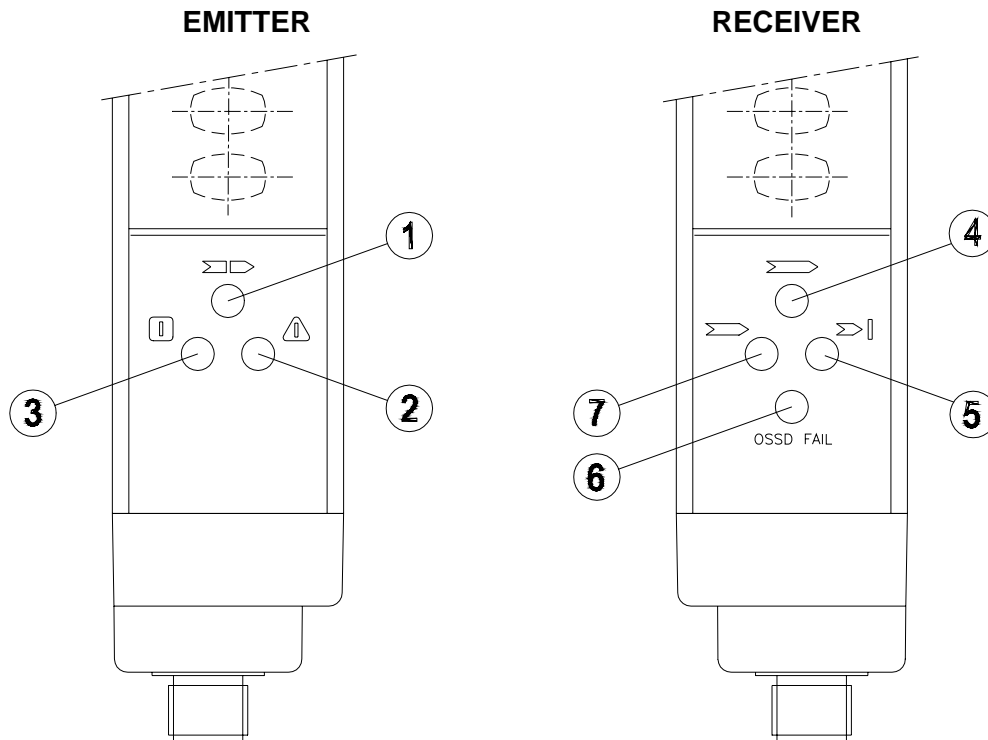

Figure 14

EMITTER SIGNALS

Normal operation

MEANING	RED (2)	GREEN (3)	(TEST) YELLOW (1)
Power on. Initial test	ON	OFF	ON
Normal operation. HIGH range	OFF	ON	OFF
TEST	OFF	ON	ON

RECEIVER SIGNALS

Normal operation

MEANING	LED			
	RED (5)	GREEN (7)	(CLEAR) YELLOW (4)	(OSSD) RED (6)
System power on. Initial TEST	ON	OFF	ON	ON
Light-on for 10sec: Manual with feedback disabled	OFF	ON	blinking every 2sec	OFF
Light-on for 10sec: Manual with feedback enabled	OFF	ON	blinking every 1/2sec	OFF
Light-on for 10sec: Automatic with feedback disabled	OFF	ON	blinking every 2sec	ON
Light-on for 10sec: Automatic with feedback enabled	OFF	ON	blinking every 1/2sec	ON
BREAK condition (A)	ON	OFF	OFF	OFF
CLEAR condition (B)	ON	OFF	ON	OFF
GUARD Condition (C)	OFF	ON	OFF	OFF

- (A) Barrier occupied - output disabled
- (B) Barrier free - output disabled - Waiting for restart
- (C) Barrier free - output enabled

Configuration errors

MEANING	LED			
	RED (5)	GREEN (7)	(CLEAR) YELLOW (4)	(OSSD) RED (6)
Customer configuration rejected	ON	OFF	4 consecutive pulses	OFF
OSSD erroneously connected to 24VDC	ON	OFF	OFF	5 consecutive pulses
External Feedback contactors missed	ON	OFF	5 consecutive pulses	OFF



On the emitter of the **Multibeam** models, near each beam, is present a red led which permits an easy detection of the beam.

TEST FUNCTION

The TEST function is available should the user wish to check equipment connected downstream of the barrier (without physically entering the protected area).

By means of this function the OSSDs can be switched from ON to OFF as long as the function remains active. Please see Table 2 (page 10) for details about the use of the test function. With the test function, which simulates occupation of the protected area, it possible to verify the operation of the entire system by means of an external supervisor (e.g. PLC, control module, etc.).

- ➔ REER recommend to operate a TEST function before each work shift to check equipment connected downstream of the barrier.
- ➔ The minimum duration of the TEST function must be 40 msec.

PERIODICAL SYSTEM TEST

According the Standard EN 61496-1, a Type 2 photoelectric barrier must carry out a periodical system test. As deccribed above, the VISION VXL barrier features an automatic self-diagnosis function which is permanently active and verify the entire VXL operation (with a periodic auto-test every **500ms**).

OUTPUT STATUS

The VISION VXL features two static PNP outputs on the Receiver, the status of which depends on the condition of the protected area.

The maximum load allowed is 500mA at 24VDC, which corresponds to a resistive load of 48Ω. Maxim load capacity corresponds to 2μF. The meaning of the status of outputs is defined in the table below. Any short circuit between outputs or between outputs and 24VDC or 0VDC power supplies is detected by the barrier.

NAME OF SIGNAL	CONDITION	MEANING
OSSD1	24VDC	Barrier clear condition
OSSD2		
OSSD1	0VDC	Barrier engaged condition or failure detected
OSSD2		

Table 5

In the protected area clear condition, the Receiver supplies a voltage of 24 VDC on both outputs. The required load must therefore be connected between the output terminals and the 0VDC (Figure 15).

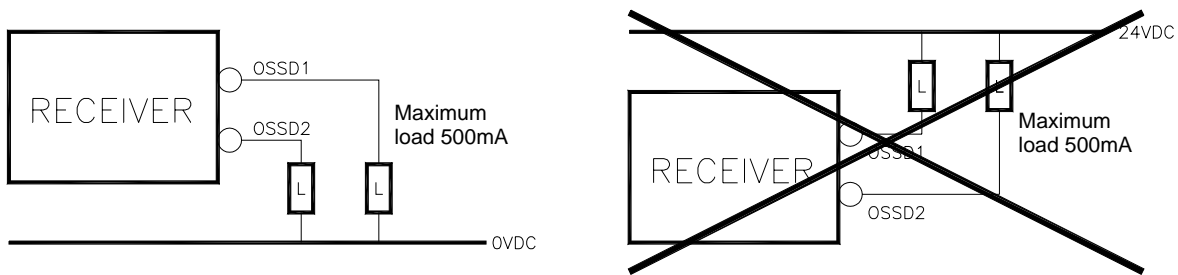

Figure 15

TECHNICAL SPECIFICATIONS

TECHNICAL SPECIFICATIONS OF VISION BARRIERS VXL		
Protected height	mm	160 – 1810
Resolutions	mm	30 – 40
Working range	m	0,3 ÷ 8
Safety outputs		2 PNP – 500mA @ 24VDC
Response time	ms	4 ÷ 37 (see tables for specific models)
Internal test frequency		every 500ms (2Hz)
Power supply	VDC	24 ± 20%
Connections		Connectors M12 5/8-poles
Max. conn. length	m	100
Operating temperature	°C	0 ÷ +55°C
Storage temperature	°C	-20 ÷ +70°C
Protection rating		IP 65
Dimensions of section	mm	35 x 45
Max. consumption	W	2 (Emitter) 2 (Receiver)
Light curtain lifetime		20 years
Safety level	Type 2	IEC 61496-1:2004 IEC 61496-2:2006
	SIL 2	IEC 61508:1998
	SILCL 2	IEC 62061:2005
	PL d - Category 2	ISO 13849-1:2006

30 mm Resolution Models	153	303	453	603	753	903	1053	1203	
Number of beams	8	16	24	32	40	48	56	64	
Response time ms	7	11,5	16	20	24	28,5	33	37	
Overall barrier ht. mm	261	411	561	711	861	1011	1161	1311	
PFHd *	2,44E-08	3,56E-08	4,68E-08	5,8E-08	6,92E-08	8,05E-08	9,17E-08	1,03E-07	
DCavg #	94,0%	93,7%	93,6%	93,5%	93,5%	93,4%	93,4%	93,4%	
MTTFd # years	100						93,24	82,22	73,53
CCF #	80%								

40 mm Resolution Models	304	454	604	754	904	1054	1204	1354	1504	1654	1804
Number of beams	10	15	20	25	30	35	40	45	50	55	60
Response time ms	8	11	13,5	16	19	22	24	27	30	32	35
Overall barrier ht. mm	411	561	711	861	1011	1161	1311	1461	1611	1761	1911
PFHd *	2,97E-08	3,79E-08	4,61E-08	5,44E-08	6,26E-08	7,08E-08	7,9E-08	8,73E-08	9,55E-08	1,04E-07	1,12E-07
DCavg #	94,0%	93,9%	93,8%	93,7%	93,7%	93,7%	93,7%	93,6%	93,6%	93,6%	93,6%
MTTFd # years	100						91,58	83,18	76,19	70,29	65,24
CCF #	80%										

Multibeam Models	VXL2B	VXL3B	VXL4B
Number of beams	2	3	4
Distance between beams mm	500	400	300
Response time ms	4	4,5	5,5
Overall barrier ht. mm	711	1011	1111
PFHd *	1,45E-08	1,52E-08	1,59E-08
DCavg #	94,7%	94,8%	94,8%
MTTFd # years	100		
CCF #	80%		

* IEC 61508
ISO 13849-1

DIMENSIONS

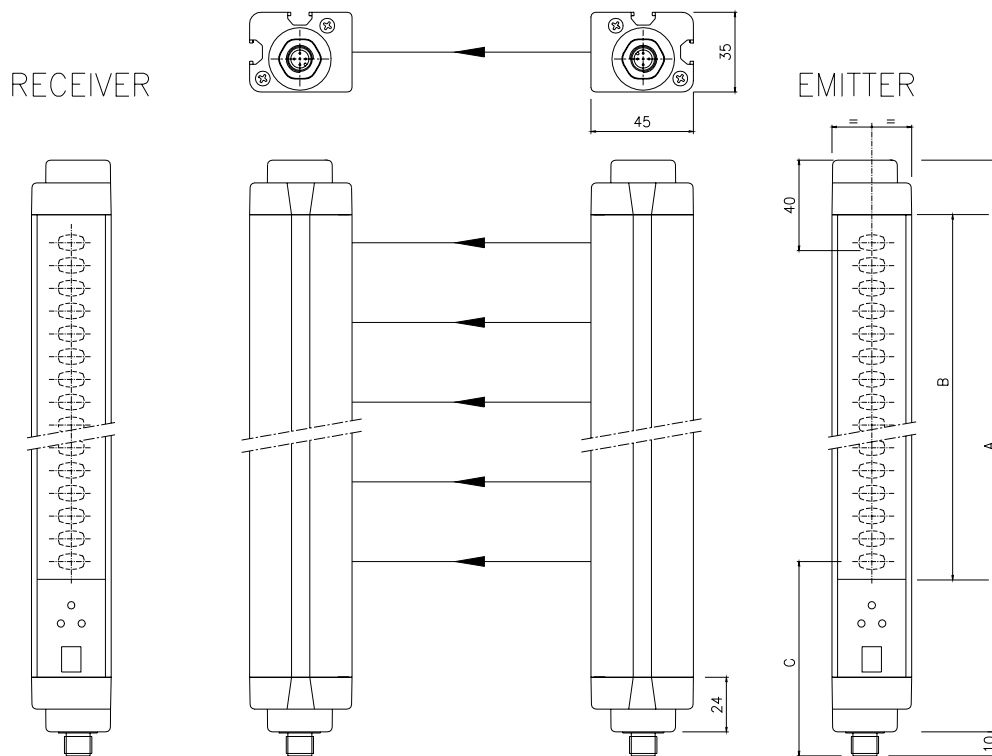

Figure 16
Emitter and Receiver

Model	150	300	450	600	750	900	1050	1200	1350	1500	1650	1800
A	251	401	551	701	851	1001	1151	1301	1451	1601	1751	1901
B (protected area)	160	310	460	610	760	910	1060	1210	1360	1510	1660	1810
C	85											
Fastening	2 LS Brackets with 2 mounting inserts						3 LS Brackets with 3 mounting inserts					

Model	VXL 2B	VXL 3B	VXL 4B
A	701	1001	1101
Distance between beams	500	400	300
C	135		

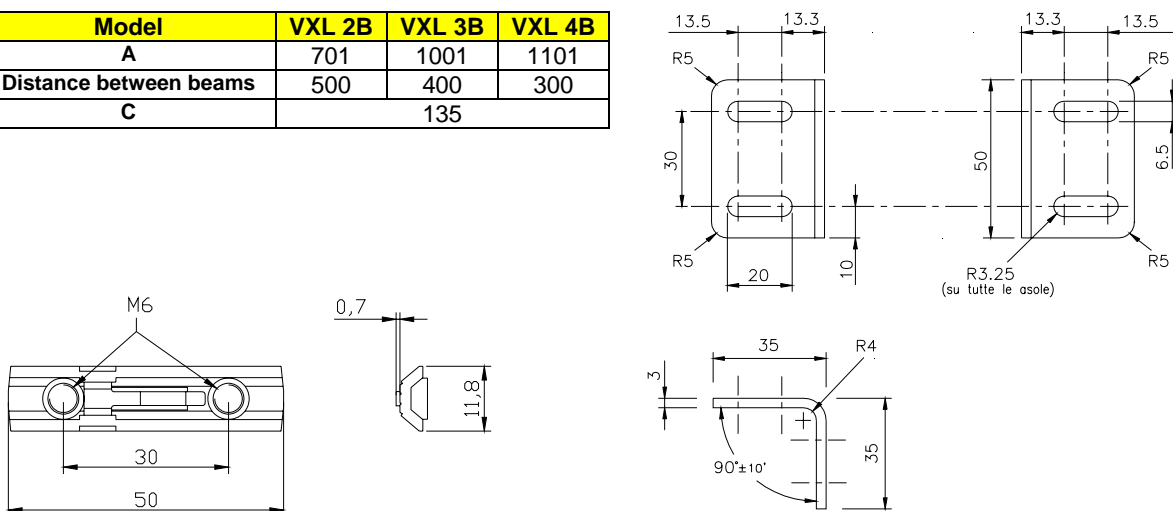

Figure 17
Fastening LS type brackets and inserts (included)

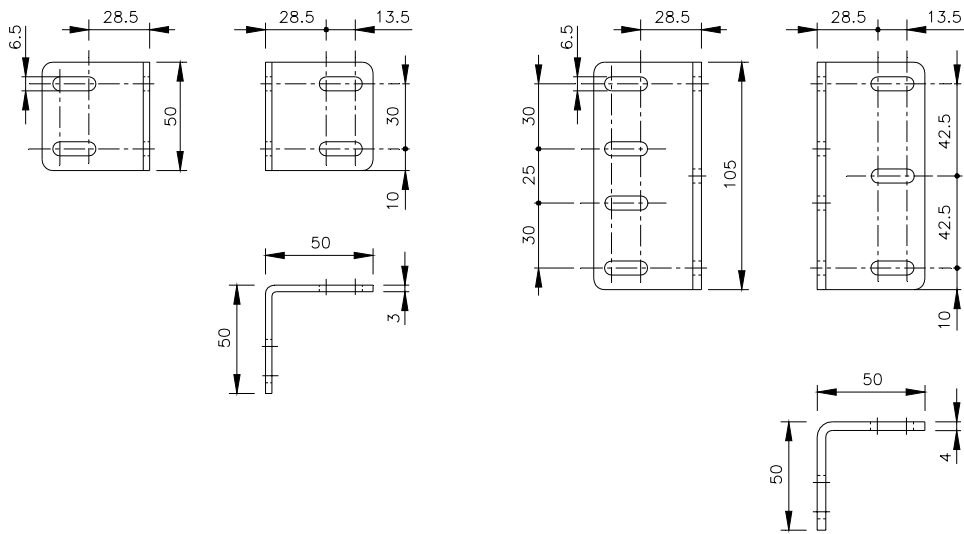

Figure 18

LL and LH TYPE fastening brackets (optional)

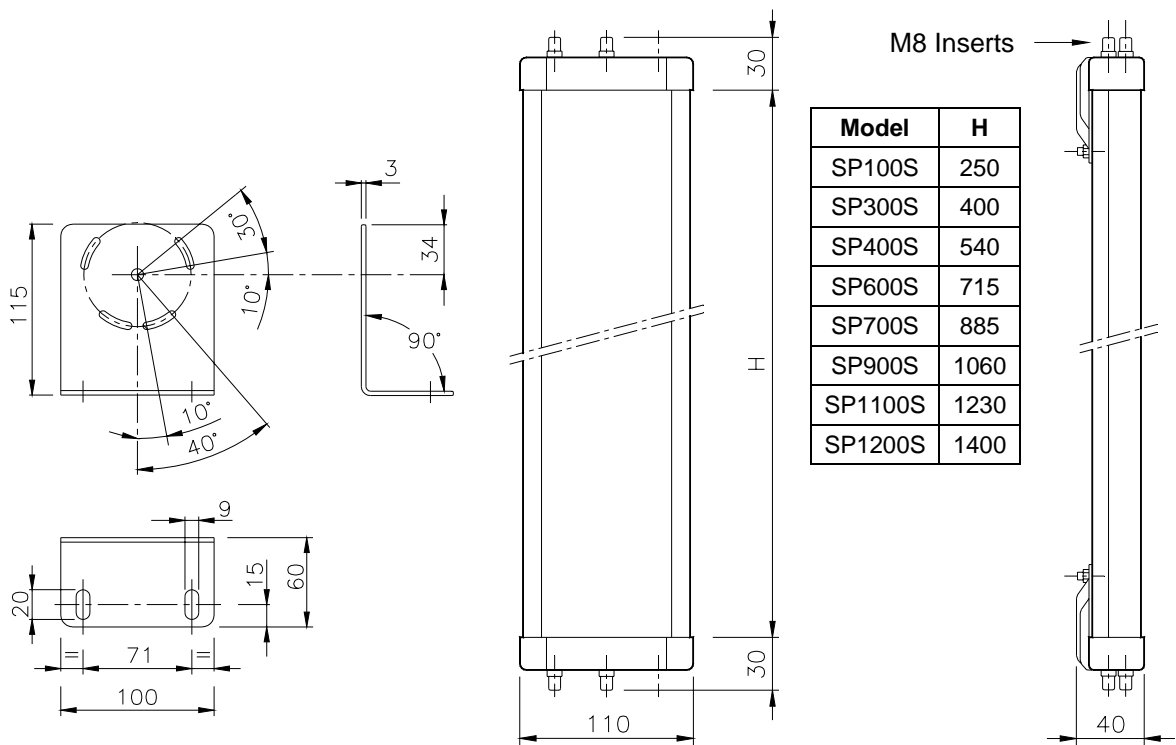

Figure 19

Fastening brackets for deviation mirrors

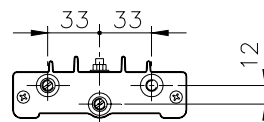

Figure 20
Deviation mirrors

CHECKOUTS AND MAINTENANCE

VERIFICATION OF BARRIER EFFICIENCY



Before each work shift or just after switching on, check the correct operation of the photoelectric barrier.

Proceed as follows, intercepting the beams using the appropriate test object (available on request).



The correct test object must be used for testing, depending on the barrier resolution. See page 26 for the correct ordering code.

Refer to Figure 21:

- Introduce the test object into the protected area and move it slowly, starting from the top and moving down (or vice versa), first in the centre and then in the vicinity of both the Emitter and the Receiver.
- **Multibeam models:**
Intercept each beam with an opaque object, first in the center of the detection zone and then close to the emitter and the receiver.
- Make sure that during each stage of the test object's movements the red LED on the Receiver is always on.

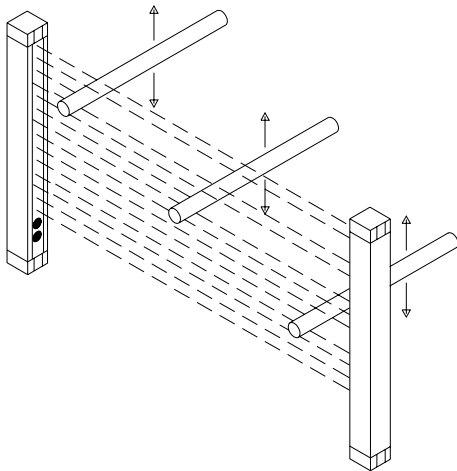

Figure 21

The VISION VXL barrier does not require any specific maintenance operations; however, periodic cleaning of the front protective surfaces of the Emitter and Receiver optics is recommended.

Wipe using a clean, damp cloth; in particularly dusty environments, after cleaning the front surface, the use of an anti-static spray is recommended.

Never use abrasive or corrosive products, solvents or alcohol, which could damage parts. Do not use woollen cloths, that could electrify the front surface.



Grooving or fine scratching of the front plastic surfaces can increase the amplitude of the emission angle of the light curtain, jeopardising detection efficiency in the presence of lateral reflecting surfaces.



It is therefore fundamental to pay particular attention during the cleaning phases of the curtain front window, especially in environments where abrasive dusts are present. (E.g. cement factories, etc).

TROUBLESHOOTING

The indications provided by the LEDs present on the Emitter and Receiver units make it possible to trace the cause of a system malfunction.

As indicated in the “**SIGNALS**” chapter of this manual, in the case of a fault, the system is blocked and the type of fault can be identified by the LEDs present on the Emitter and Receiver units. (See the tables below).

EMITTER

MEANING	LED			REMEDY
	RED (2)	GREEN (3)	(TEST) YELLOW (1)	
Internal error (add-on board)	ON	OFF	blinking every 2,5sec	Send the equipment for repair to the REER laboratories.
Internal error (master board)	ON	OFF	blinking every 0,8sec	

RECEIVER

MEANING	LED				REMEDY
	RED (5)	GREEN (7)	(CLEAR) YELLOW (4)	(OSSD) RED (6)	
Internal error	ON	OFF	2 / 3 consecutive pulses	OFF	Send the equipment for repair to the REER laboratories.
OSSD static outputs error	ON	OFF	OFF	2 consecutive pulses	Carefully check the connection of terminals 1 and 3 (OSSD) on the connector. If necessary, adjust load reducing the current required to max 500 mA (2μF)
Overload of the OSSD static outputs	ON	OFF	OFF	3 consecutive pulses	Carefully check the connection of terminals 1 and 3 (OSSD) on the connector. If necessary, adjust load reducing the current required to max 500 mA (2μF)
OSSD1 - OSSD2 short-circuit	ON	OFF	OFF	4 consecutive pulses	Carefully check the connection of terminals 1 and 3
Interfering dangerous Emitter detected. The receiver is able to receive simultaneously the beams from two different Emitters	ON	OFF	6 consecutive pulses	OFF	Carefully locate the interfering Emitter and take action in one of the following ways: <ul style="list-style-type: none"> • Switch the position of the Emitter and Receiver. • Move the interfering Emitter to avoid this illuminating the Receiver. • Shield the beams coming from the interfering Emitter using opaque protections.

In any case, when faced with a system stoppage, switch the system off and then on again, to exclude any occasional electromagnetic disturbances.

Should the problem persist, contact REER's service department. In case of continued malfunctioning:

- make sure that the Emitter and the Receiver are correctly aligned and that the front surfaces are perfectly clean.
- verify the integrity of electrical connections and check that these have been made correctly;
- check that the supply voltage levels comply with those specified in the technical data sheet;
- the barrier power supply should be kept separate from that of the other electric power equipment (electric motors, inverters, frequency converters) or other sources of disturbance.



If it is not possible to clearly identify the malfunction and to remedy it, stop the machine and contact Reer's Assistance Service.

If correct system operation cannot be restored after carrying out the above procedures, send the equipment to REER's laboratories, complete with all parts, stating clearly:

- the product code number (the **P/N** field is shown on the product label)
- serial number (the **S/N** field is shown on the product label)
- date of purchase;
- period of operation;
- type of application;
- fault.

SPARE PARTS

MODEL	ARTICLE	CODE
AD SR0	AD SR0 Safety Relay	1330902
AD SR0A	AD SR0A Safety Relay	1330903
CD5	Straight 5-pin M12 female connector, 5 m cable	1330950
CD95	90° 5-pin M12 female connector, 5 m cable	1330951
CD15	Straight 5-pin M12 female connector, 15 m cable	1330952
CD915	90° 5-pin M12 female connector, 15 m cable	1330953
CDM9	Straight 5-pin M12 female connector PG9	1330954
CDM99	90° 5-pin M12 female connector PG9	1330955
C8D5	Straight 8-pin M12 female connector, 5 m cable	1330980
C8D10	Straight 8-pin M12 female connector, 10 m cable	1330981
C8D15	Straight 8-pin M12 female connector, 15 m cable	1330982
C8D95	90° 8-pin M12 female connector, 5 m cable	1330983
C8D910	90° 8-pin M12 female connector, 10 m cable	1330984
C8D915	90° 8-pin M12 female connector, 15 m cable	1330985
C8DM9	Straight 8-pin M12 female connector PG9	1330986
C8DM99	90° 8-pin M12 female connector PG9	1330987
TR14	14mm diameter test rod	1330960
TR20	20mm diameter test rod	1330961
TR30	30mm diameter test rod	1330962
TR40	40mm diameter test rod	1330963
TR50	50mm diameter test rod	1330964
FB 4	Set of 4 fastening brackets	1330970
FB 6	Set of 6 fastening brackets	1330971
LL	Set of 4 fastening brackets LL type	7200037
LH	Set of 4 fastening brackets LH type	7200081
FI 4	Set of 4 fastening inserts	1330972
FI 6	Set of 6 fastening inserts	1330973
SFB	Set of 4 swivel fastening brackets	1330974
SAV-3	Set of 2 anti-vibration supports	1200088
SAV-4	Set of 3 anti-vibration supports	1200089

GUARANTEE

All new VISION VXL systems are guaranteed by REER for a period of 12 (twelve) months under normal working conditions, against defects due to faulty materials and workmanship. During the aforesaid period, REER promises to replace faulty parts free of charge. This guarantee covers both material and labour. REER reserves the right to decide whether to repair equipment or replace it with equipment of the same type or having the same characteristics.

The validity of this guarantee is subject to the following conditions:

- The user must notify REER of the fault within twelve months following the date of delivery of the product.
- The equipment and all parts thereof must be in the condition in which they were supplied by REER.
- The defect or malfunction must not arise directly or indirectly from:
 - Improper use
 - Non-observance of the instructions for use;
 - Negligence, inexperience, improper maintenance;
 - Repairs, modifications and adjustments carried out by personnel not authorised by REER, tampering, etc.;
 - Accidents or collisions (also during transportation or due to acts of God);
 - Other reasons for which REER cannot be held responsible.

Repairs will be carried out at REER's laboratories, to which the material must be consigned or forwarded: transport costs and any damage or loss of material during transportation will be charged to the Customer.

All replaced products and parts are property of REER.

REER does not recognise any other form of guarantee or rights other than those expressly stated above; no requests for compensation for damages incurred for costs, suspension of activities or any other events or circumstances related in any way to malfunctioning of the product or any parts thereof will be taken into consideration.

In order to ensure the correct operation of the photoelectric barrier, careful and full compliance with all the rules, instructions and warnings stated in this manual is essential.

REER s.p.a. declines all responsibility for events arising from non-compliance with all or part of the aforesaid instructions.

Specifications subject to change without warning. • No part of this manual may be reproduced without the prior consent of REER.