

2 x  $\phi$  .130 x .300 Dp.  
M4x0.7 - 6H x .250 Dp.

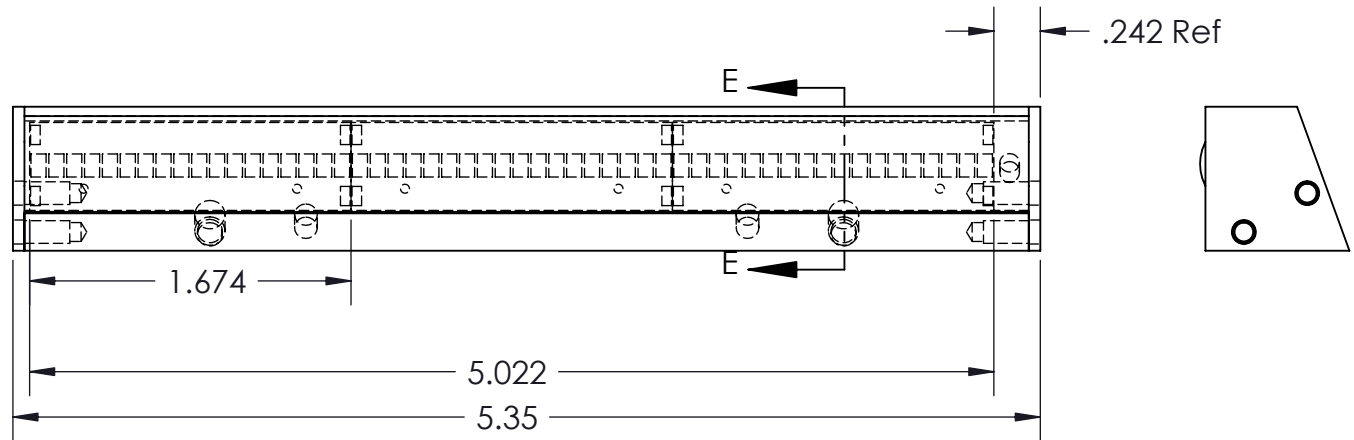
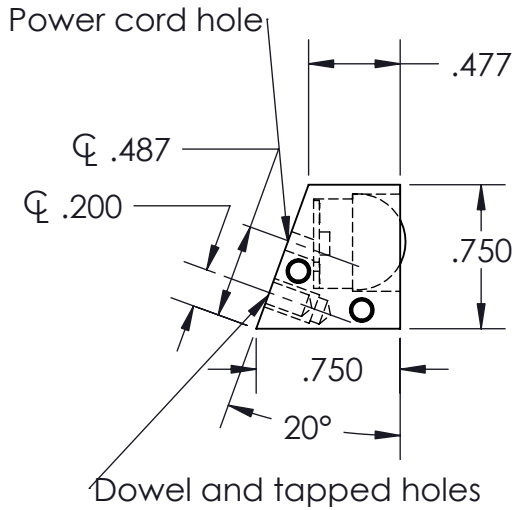
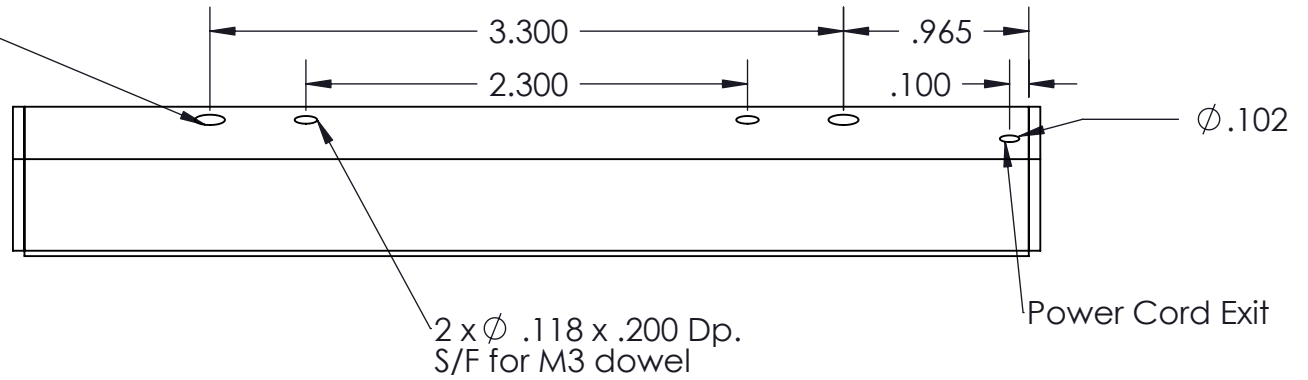

Notes:

1. All parts and materials to be ROHS compliant
2. 24v White + / Black -
3. Current draw: 360mA
4. Cord length: 1.5m
5. Wire termination: 22ga. Ferrule
6. Polarity Label (White+/Bare-) placed  $3'' \pm 1''$  from termination ferrule
7. Cognex ID: (DM100-WPSTL-000)

ITEM NO.	PART NUMBER	QTY.
1	18966.101 Heatsink	1
2	18789.630 D Lens	1
3	18966.102 Endplate	2
4	2430.01 SMD Board 1.6in	3

REV	DESCRIPTION	ECN	DATE
E3	Added notes 6&7	TSD	10-18-07
E2	3 -1.6 Long Board was 1 - 4.2	TSD	9-28-07



FINISH	DWN. TSD	UNLESS OTHERWISE SPECIFIED DIM ARE IN INCHES	SHEET 1:1
MATERIAL	DATE 6-29-07		
ALL MACHINED SURFACE 63	APPROVED		
	SCALE	FRACT. $\pm 1/16$ XX $\pm 0.01$ XXX $\pm 0.005$ angle $\pm 1/2^\circ$	

INFORMATION HEREIN IS PROPRIETARY TO VOLPI MANUFACTURING AND CANNOT BE REPRODUCED OR USED IN ANY MANNER WITHOUT SPECIFIC WRITTEN APPROVAL OF VOLPI MANUFACTURING USA

SIZE A	DESC. 20Deg White SMD LL	DWG. NO. 18966.000	REV E3
--------	--------------------------	--------------------	--------